

VIEW FROM "A"

- 1 - Coolant inlet (G1/8")
 - 2 - Coolant outlet (G1/8")
 - 3 - Hydraulic pressure unclamping tool (50bar max) (G1/4")
 - 4 - Inlet air arbor's cleaning (6 bar) (G1/8")
 - 5 - Electric connection
3Phases motor - Earth
 - 6 - Outlet sensor's cables (S1-S2-S4)
(Veam VPT01W14-12P/VPT 06W14-12S)
 - S1 = Tool's arbor clamped.
 - S2 = Piston under pressure ready to receive tools arbor.
The electrospindle can not turn.
 - S4 = Tool's arbor unclamped.
- Thermich Sensor Bearings
- 7 - Front-side pressurization (G1/8")
 - 8 - Front bearings lubrication 1 (G1/8")
 - 9 - Front bearings lubrication 2 (G1/8")
 - 10 - Rear bearings lubrication 1 (G1/8")
 - 11 - Unloading lubrication bearings (G1/8")
 - 12 - Rear bearings lubrication 2 (G1/8")
 - 13 - Front bearings lubrication 3 (G1/8")
 - 14 - Outlet encoder's cables (Gel 2442 KN)
Motor thermich switch (N°2 KTY)
(6FX2 003-1CF17/6FX 003-0CE17)

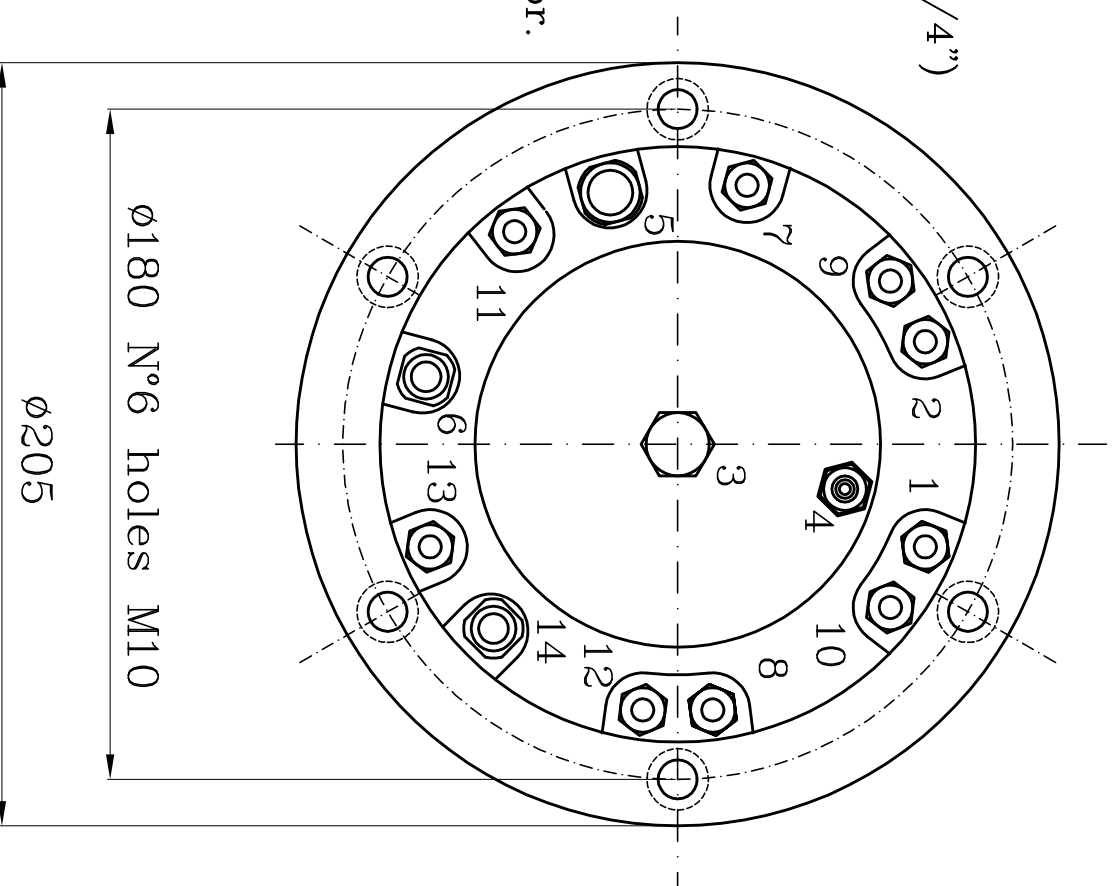

DERON
SPEED

SUBJECT : PS-TCV-3

CUSTOMER :

SHEET : 2/3

DATE : 02/03/2006