

VIEW FROM "A"

- 1 - Coolant inlet (G1/8")
  - 2 - Coolant outlet (G1/8")
  - 3 - Hydraulic pressure unclamping tool (50bar max) (G1/4")
  - 4 - Hydraulic pressure piston return (50 bar) (G1/4")
  - 5 - Electric connection  
3Phases motor - Earth
  - 6 - Outlet sensor's cables (S1-S2-S4)  
(Veam VPT01W14-12P/VPT 06W14-12S)  
S1 = Tool's arbor clamped.  
S2 = Piston under pressure ready to receive tools arbor.  
The electrospindle can not turn.  
S4 = Tool's arbor unclamped.
- Themic sensor bearings
- 7 - Front-side pressurization (G1/8")
  - 8 - Lubro-coolant inlet for external tool (G1/8")
  - 9 - Front bearings lubrication 1 (G1/8")
  - 10 - Front bearings lubrication 2 (G1/8")
  - 11 - Rear bearings lubrication 1 (G1/8")
  - 12 - Unloading lubrication bearings (G1/8")
  - 13 - Rear bearings lubrication 2 (G1/8")
  - 14 - Front bearings lubrication 3 (G1/8")
  - 15 - Outlet cables encoder (Gel 244 KN)  
Motor thermic switch (N°2 KTY)  
(6FX2 003-1CF17/6FX 003-0CE17)
  - 16 - Inlet internal lubrorrefrigeration by joint (G1/4")  
+ inlet air arbor cleaning
  - 17 - Rotary joint leakage outlet

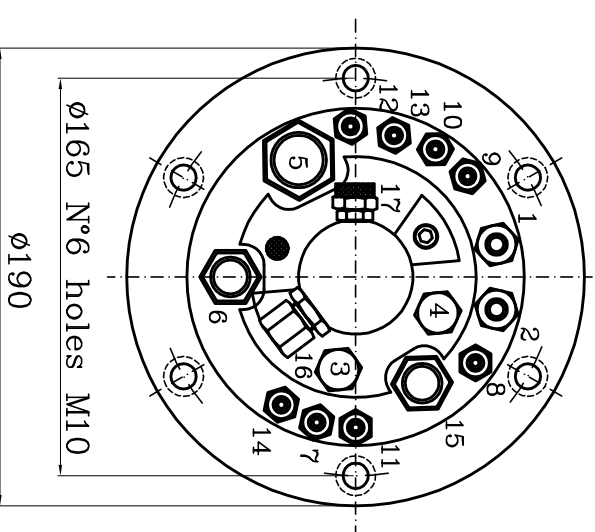

SUBJECT : PS-TCV-1  
CUSTOMER: