

- A-Coolant inlet-outlet
- B-Double effect tool's release hydraulic cylinder inlet
- C-Electrical motor connections
- D-Sensor S1-S2-S4 cables to check the tool change operation
- E-Front spindle and rotary joint (option) pressurisation
- F-External tool's Lubrorefrigeration
- G-Air-oil Lubrication of each bearing's inlet
- H-Outflow oil
- I-Encoder cables and HF motor thermal switches exit
- L-Tool's Lubrorefrigeration through the centre by rotary joint and arbor's air cleaning
- M-Rotary joint leakage outlet

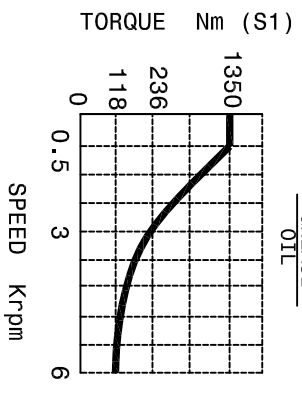

- Synchronous motor 12 poles
- Max power 72 Kw
- Max torque 1350 Nm
- Tension 425 V
- Max current 265 A
- Max frequency 600 Hz
- N°3 Ø 100 front hybrid ceramic bearings
- Bearings's Lubrication by permanent grease or air-oil for high speeds
- Internal cooling by liquid circuit
- Automatic clamping tools
- Required cooling capacity 15000 Watt
- Weight Kg 400

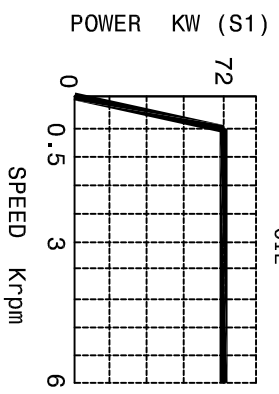
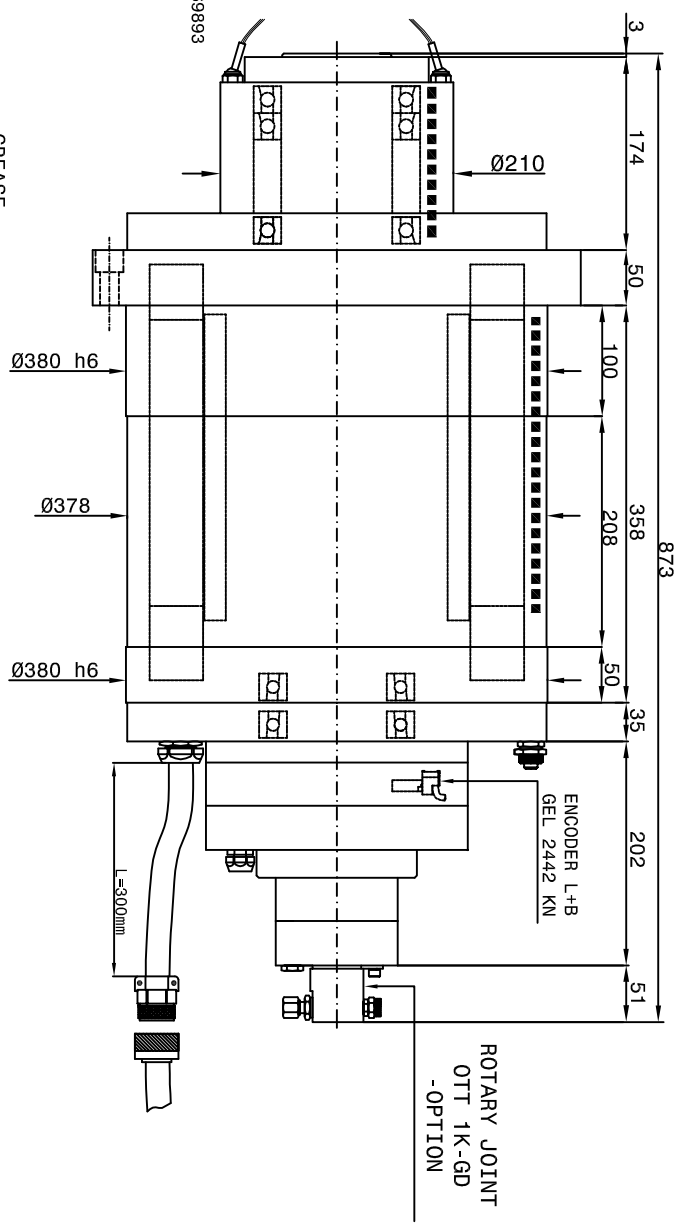
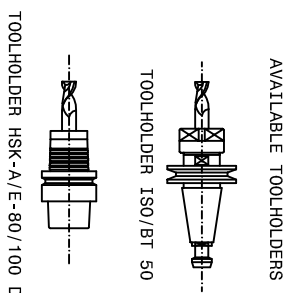

SUBJECT: PS-TCV-11
CUSTOMER: